

More Zinc is NOT the Solution

Effective Cathodic Protection Design and Choice of Anodes.

The effective use of an internal cathodic protection bonding system and the correct choice of anodes can significantly reduce many of the problems stemming from over protection and also reduce the gross number of anodes required to protect a vessel.

Many fibreglass vessels have “noble” shafts, propellers and hull metallic fittings. The Galvanic Series of Metals highlights the voltage that these metals generate in water, whilst the ABYC standards denote a minimum 200mV shift relative to the least noble metal being protected. However, the over protection of these metals can cause significant issues such as paint and coating blasting, attract marine growths and effectively reduce the efficiency of the vessel.

Maddox anodes eliminate the costs of over protection having a much lower electronegative potential than common zinc, aluminium and magnesium anodes. Care must be taken to ensure that the anodes used to protect the fittings are a minimum 200mV shift relative to the least noble metal being protected whilst also taking into account over protection considerations at the other end.

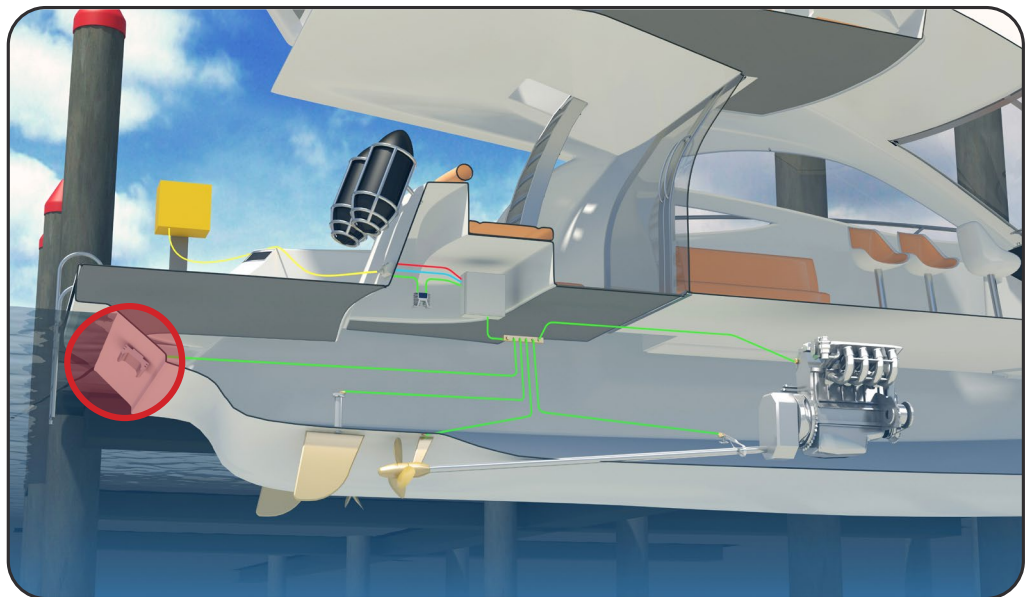
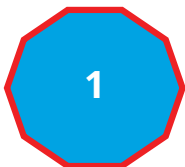

Through the use of a bonding system (as illustrated above) an effective closed circuit can be created and reduce the number of anodes required under traditional methodologies which use a greater number of anodes (see below).

8

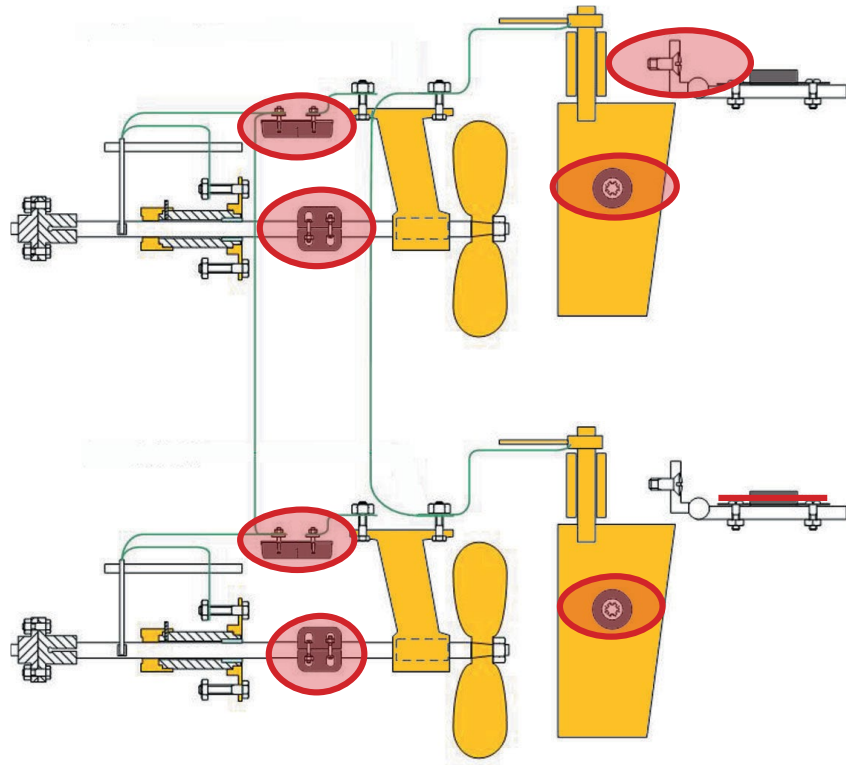

This material remains the exclusive property of Marine Protection Systems Pty Ltd and must not be reproduced, replicated, copied or used without the expressed consent of Marine Protection Systems Pty Ltd © 2011

 @marineprotectionsystems

 @marineprotectionsystems

 info@marineprosystems.com

CORROSION CONTROL THAT WORKS